

TOOLS & MATERIALS

- Tools & materials for setting posts (page 24)
- Cordless drill or screwdriver
- Level
- PVC vinyl fencing materials
- Duct tape
- #3 rebar
- Rebar separator clips
- Construction adhesive

HOW TO INSTALL VINYL FENCING

NOTE: These are general installation tips. Refer to the manufacturer's instructions for your specific fence style.

Step A: Prepare the Materials

1. Mark the fence line (pages 18 to 19), spacing the post hole locations according to the manufacturer's recommendations.
2. Sort and check the materials to be sure you have received all the proper fence pieces and hardware.
3. Cover both ends of each stringer with duct tape. Make sure there are no gaps or holes that would allow concrete to seep into the stringer later when you fill the posts.

Step B: Assemble the Panels

1. Insert the panel pieces into the pre-routed holes of the bottom stringer. Make sure each piece fits securely. If not, add duct tape to the bottom of the pieces so the fit is tighter.
2. Attach the top stringer to the panels. Work from one end and adjust the panel pieces to fit into the pre-routed holes. Make sure the stringer fits tightly around the panel pieces.
3. Secure the stringer to the panels with the self-tapping screws provided by the manufacturer.

Step C: Set the First Post

1. Position the first post. Because the posts are manufactured to size, the posts must sit precisely at the height of the fence. If a post is too high, lay a board over the top and gently tap it down, using a rubber mallet. If it's too low, add gravel beneath it. Be sure to leave enough room for a 2" gap between the bottom of the fence and the ground.
3. Mix concrete in a wheelbarrow or mixing trough, and set the post (pages 24 to 25). Use a level to make sure the post is plumb on adjacent sides. Brace the plumbed post into position with stakes and scrap pieces of 2 x 4 tied or taped to the post. Let the concrete cure.

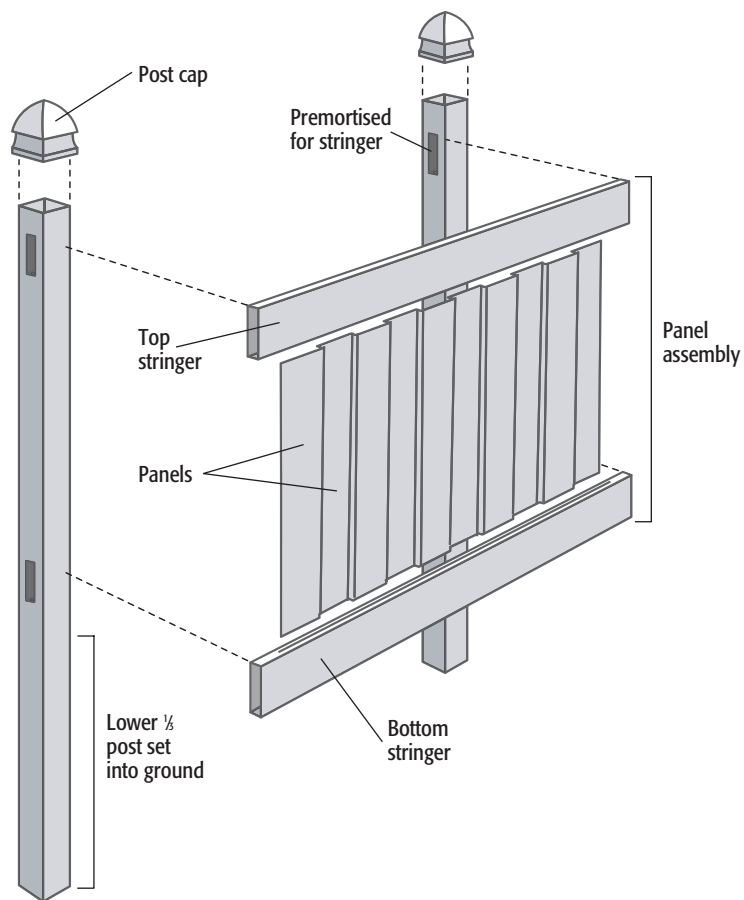

A. Place tape over the ends of the lower stringers so concrete cannot seep into them from the posts.